

. 6 . Current and Voltage Transformers

Introduction	6.1
Electromagnetic voltage transformers	6.2
Capacitor voltage transformers	6.3
Current transformers	6.4
Novel instrument transformers	6.5

• 6 • Current and Voltage

Transformers

6.1 INTRODUCTION

Whenever the values of voltage or current in a power circuit are too high to permit convenient direct connection of measuring instruments or relays, coupling is made through transformers. Such 'measuring' transformers are required to produce a scaled down replica of the input quantity to the accuracy expected for the particular measurement; this is made possible by the high efficiency of the transformer. The performance of measuring transformers during and following large instantaneous changes in the input quantity is important, in that this quantity may depart from the sinusoidal waveform. The deviation may consist of a step change in magnitude, or a transient component that persists for an appreciable period, or both. The resulting effect on instrument performance is usually negligible, although for precision metering a persistent change in the accuracy of the transformer may be significant.

However, many protection systems are required to operate during the period of transient disturbance in the output of the measuring transformers that follows a system fault. The errors in transformer output may abnormally delay the operation of the protection, or cause unnecessary operations. The functioning of such transformers must, therefore, be examined analytically.

It can be shown that the transformer can be represented by the equivalent circuit of Figure 6.1, where all quantities are referred to the secondary side.

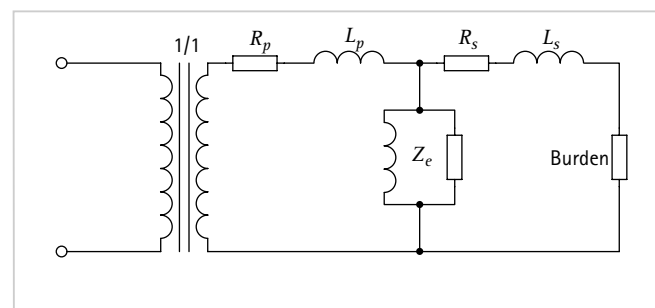

Figure 6.1: Equivalent circuit of transformer

When the transformer is not 1/1 ratio, this condition can be represented by energising the equivalent circuit with an ideal transformer of the given ratio but having no losses.

6.1.1 Measuring Transformers

Voltage and current transformers for low primary voltage or current ratings are not readily distinguishable; for higher ratings, dissimilarities of construction are usual. Nevertheless the differences between these devices lie principally in the way they are connected into the power circuit. Voltage transformers are much like small power transformers, differing only in details of design that control ratio accuracy over the specified range of output. Current transformers have their primary windings connected in series with the power circuit, and so also in series with the system impedance. The response of the transformer is radically different in these two modes of operation.

6.2 ELECTROMAGNETIC VOLTAGE TRANSFORMERS

In the shunt mode, the system voltage is applied across the input terminals of the equivalent circuit of Figure 6.1. The vector diagram for this circuit is shown in Figure 6.2.

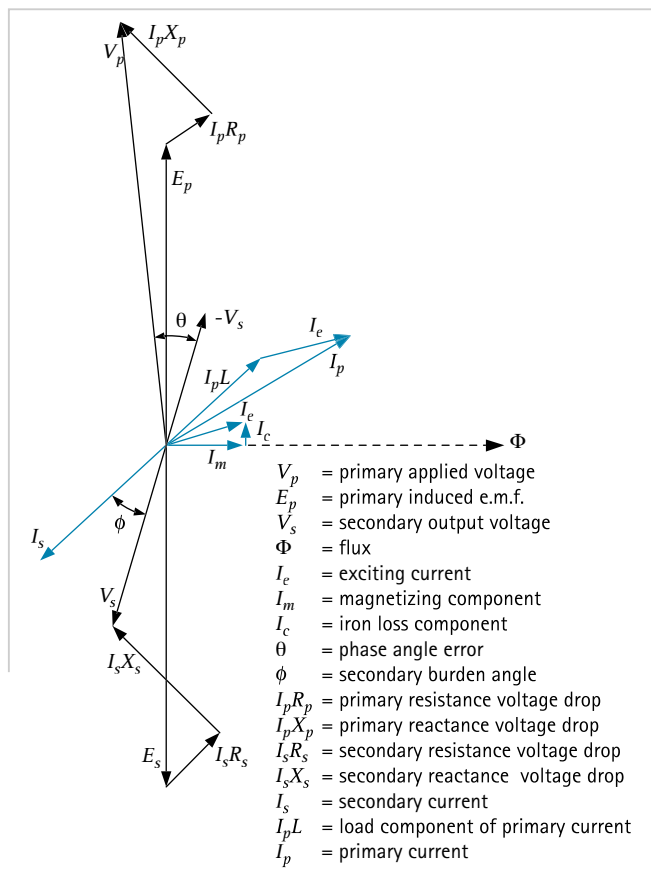

Figure 6.2: Vector diagram for voltage transformer

The secondary output voltage V_s is required to be an accurate scaled replica of the input voltage V_p over a specified range of output. To this end, the winding

voltage drops are made small, and the normal flux density in the core is designed to be well below the saturation density, in order that the exciting current may be low and the exciting impedance substantially constant with a variation of applied voltage over the desired operating range including some degree of overvoltage. These limitations in design result in a VT for a given burden being much larger than a typical power transformer of similar rating. The exciting current, in consequence, will not be as small, relative to the rated burden, as it would be for a typical power transformer.

6.2.1 Errors

The ratio and phase errors of the transformer can be calculated using the vector diagram of Figure 6.2.

The ratio error is defined as:

$$\frac{(K_n V_s)}{V_p} \times 100\%$$

where:

K_n is the nominal ratio

V_p is the primary voltage

V_s is the secondary voltage

If the error is positive, the secondary voltage exceeds the nominal value. The turns ratio of the transformer need not be equal to the nominal ratio; a small turns compensation will usually be employed, so that the error will be positive for low burdens and negative for high burdens.

The phase error is the phase difference between the reversed secondary and the primary voltage vectors. It is positive when the reversed secondary voltage leads the primary vector. Requirements in this respect are set out in IEC 60044-2. All voltage transformers are required to comply with one of the classes in Table 6.1.

For protection purposes, accuracy of voltage measurement may be important during fault conditions, as the system voltage might be reduced by the fault to a low value. Voltage transformers for such types of service must comply with the extended range of requirements set out in Table 6.2.

Accuracy class	0.8 - 1.2 x rated voltage 0.25 - 1.0 x rated burden at 0.8pf	
	voltage ratio error (%)	phase displacement (minutes)
0.1	+/- 0.1	+/- 5
0.2	+/- 0.2	+/- 10
0.5	+/- 0.5	+/- 20
1.0	+/- 1.0	+/- 40
3.0	+/- 3.0	not specified

Table 6.1: Measuring voltage transformer error limits

Accuracy class	0.25 - 1.0 x rated burden at 0.8pf 0.05 - V_f x rated primary voltage	
	voltage ratio error (%)	phase displacement (%)
3P	+/- 3.0	+/- 120
6P	+/- 6.0	+/- 240

Table 6.2: Additional limits for protection voltage transformers.

6.2.2 Voltage Factors

The quantity V_f in Table 6.2 is an upper limit of operating voltage, expressed in per unit of rated voltage. This is important for correct relay operation and operation under unbalanced fault conditions on unearthed or impedance earthed systems, resulting in a rise in the voltage on the healthy phases.

Voltage factors, with the permissible duration of the maximum voltage, are given in Table 6.3.

Voltage factor V_f	Time rating	Primary winding connection/system earthing conditions
1.2	continuous	Between lines in any network. Between transformer star point and earth in any network
1.2	continuous	Between line and earth in an effectively earthed network
1.5	30 s	
1.2	continuous	Between line and earth in a non-effectively earthed neutral system with automatic earth fault tripping
1.9	30 s	
1.2	continuous	Between line and earth in an isolated neutral system without automatic earth fault tripping, or in a resonant earthed system without automatic earth fault tripping
1.9	8 hours	

Table 6.3: Voltage transformers: Permissible duration of maximum voltage

6.2.3 Secondary Leads

Voltage transformers are designed to maintain the specified accuracy in voltage output at their secondary terminals. To maintain this if long secondary leads are required, a distribution box can be fitted close to the VT to supply relay and metering burdens over separate leads. If necessary, allowance can be made for the resistance of the leads to individual burdens when the particular equipment is calibrated.

6.2.4 Protection of Voltage Transformers

Voltage Transformers can be protected by H.R.C. fuses on the primary side for voltages up to 66kV. Fuses do not usually have a sufficient interrupting capacity for use with higher voltages. Practice varies, and in some cases protection on the primary is omitted.

The secondary of a Voltage Transformer should always be protected by fuses or a miniature circuit breaker (MCB). The device should be located as near to the transformer

as possible. A short circuit on the secondary circuit wiring will produce a current of many times the rated output and cause excessive heating. Even where primary fuses can be fitted, these will usually not clear a secondary side short circuit because of the low value of primary current and the minimum practicable fuse rating.

6.2.5 Construction

The construction of a voltage transformer takes into account the following factors:

- a. output – seldom more than 200-300VA. Cooling is rarely a problem
- b. insulation – designed for the system impulse voltage level. Insulation volume is often larger than the winding volume
- c. mechanical design – not usually necessary to withstand short-circuit currents. Must be small to fit the space available within switchgear

Three-phase units are common up to 36kV but for higher voltages single-phase units are usual. Voltage transformers for medium voltage circuits will have dry type insulation, but for high and extra high voltage systems, oil immersed units are general. Resin encapsulated designs are in use on systems up to 33kV. Figure 6.3 shows a typical voltage transformer.



Figure 6.3: Typical voltage transformer

6.2.6 Residually Connected Voltage Transformers

The three voltages of a balanced system summate to zero, but this is not so when the system is subject to a single-phase earth fault. The residual voltage of a system is measured by connecting the secondary windings of a VT in 'broken delta' as shown in Figure 6.4.

The output of the secondary windings connected in broken delta is zero when balanced sinusoidal voltages are applied, but under conditions of unbalance a residual

voltage equal to three times the zero sequence voltage of the system will be developed.

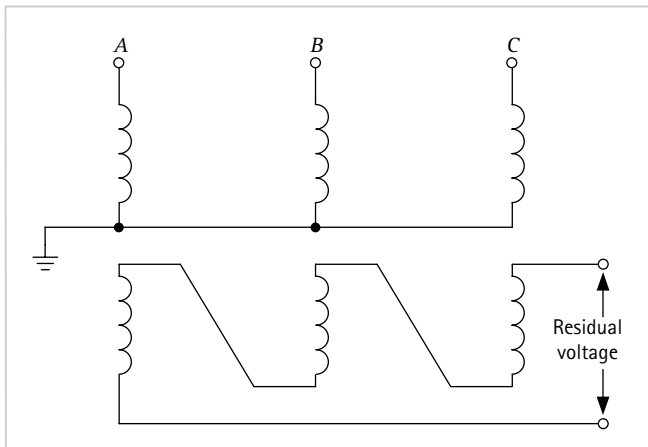

Figure 6.4: Residual voltage connection

In order to measure this component, it is necessary for a zero sequence flux to be set up in the VT, and for this to be possible there must be a return path for the resultant summated flux. The VT core must have one or more unwound limbs linking the yokes in addition to the limbs carrying windings. Usually the core is made symmetrically, with five limbs, the two outermost ones being unwound. Alternatively, three single-phase units can be used. It is equally necessary for the primary winding neutral to be earthed, for without an earth, zero sequence exciting current cannot flow.

A VT should be rated to have an appropriate voltage factor as described in Section 6.2.2 and Table 6.3, to cater for the voltage rise on healthy phases during earth faults.

Voltage transformers are often provided with a normal star-connected secondary winding and a broken-delta connected 'tertiary' winding. Alternatively the residual voltage can be extracted by using a star/broken-delta connected group of auxiliary voltage transformers energised from the secondary winding of the main unit, providing the main voltage transformer fulfils all the requirements for handling a zero sequence voltage as previously described. The auxiliary VT must also be suitable for the appropriate voltage factor. It should be noted that third harmonics in the primary voltage wave, which are of zero sequence, summate in the broken-delta winding.

6.2.7 Transient Performance

Transient errors cause few difficulties in the use of conventional voltage transformers although some do occur. Errors are generally limited to short time periods following the sudden application or removal of voltage from the VT primary.

If a voltage is suddenly applied, an inrush transient will occur, as with power transformers. The effect will, however, be less severe than for power transformers because of the lower flux density for which the VT is designed. If the VT is rated to have a fairly high voltage factor, little inrush effect will occur. An error will appear in the first few cycles of the output current in proportion to the inrush transient that occurs.

When the supply to a voltage transformer is interrupted, the core flux will not readily collapse; the secondary winding will tend to maintain the magnetising force to sustain this flux, and will circulate a current through the burden which will decay more or less exponentially, possible with a superimposed audio-frequency oscillation due to the capacitance of the winding. Bearing in mind that the exciting quantity, expressed in ampere-turns, may exceed the burden, the transient current may be significant.

6.2.8 Cascade Voltage Transformers

The capacitor VT (section 6.3) was developed because of the high cost of conventional electromagnetic voltage transformers but, as shown in Section 6.3.2, the frequency and transient responses are less satisfactory than those of the orthodox voltage transformers. Another solution to the problem is the cascade VT (Figure 6.5).

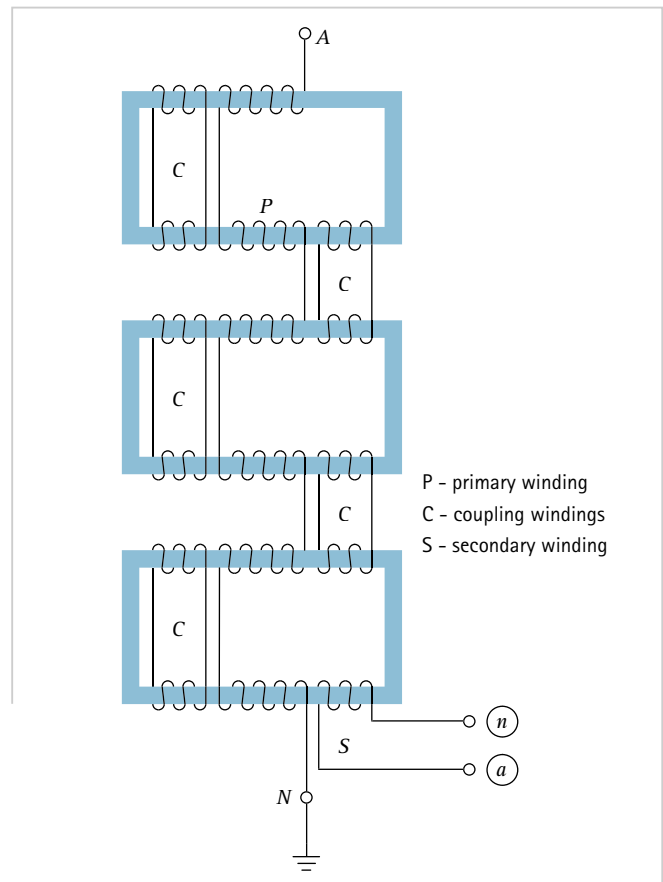

Figure 6.5: Schematic diagram of typical cascade voltage transformer

The conventional type of VT has a single primary winding, the insulation of which presents a great problem for voltages above about 132kV. The cascade VT avoids these difficulties by breaking down the primary voltage in several distinct and separate stages.

The complete VT is made up of several individual transformers, the primary windings of which are connected in series, as shown in Figure 6.5. Each magnetic core has primary windings (P) on two opposite sides. The secondary winding (S) consists of a single winding on the last stage only. Coupling windings (C) connected in pairs between stages, provide low impedance circuits for the transfer of load ampere-turns between stages and ensure that the power frequency voltage is equally distributed over the several primary windings.

The potentials of the cores and coupling windings are fixed at definite values by connecting them to selected points on the primary windings. The insulation of each winding is sufficient for the voltage developed in that winding, which is a fraction of the total according to the number of stages. The individual transformers are mounted on a structure built of insulating material, which provides the interstage insulation, accumulating to a value able to withstand the full system voltage across the complete height of the stack. The entire assembly is contained in a hollow cylindrical porcelain housing with external weather-sheds; the housing is filled with oil and sealed, an expansion bellows being included to maintain hermetic sealing and to permit expansion with temperature change.

6.3 CAPACITOR VOLTAGE TRANSFORMERS

The size of electromagnetic voltage transformers for the higher voltages is largely proportional to the rated voltage; the cost tends to increase at a disproportionate rate. The capacitor voltage transformer (CVT) is often more economic.

This device is basically a capacitance potential divider. As with resistance-type potential dividers, the output voltage is seriously affected by load at the tapping point. The capacitance divider differs in that its equivalent source impedance is capacitive and can therefore be compensated by a reactor connected in series with the tapping point. With an ideal reactor, such an arrangement would have no regulation and could supply any value of output.

A reactor possesses some resistance, which limits the output that can be obtained. For a secondary output voltage of 110V, the capacitors would have to be very large to provide a useful output while keeping errors within the usual limits. The solution is to use a high secondary voltage and further transform the output to

the normal value using a relatively inexpensive electromagnetic transformer. The successive stages of this reasoning are indicated in Figure 6.6.

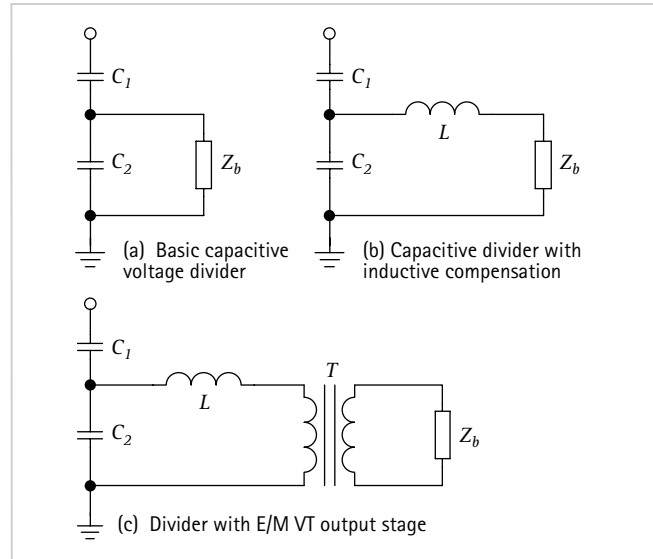

Figure 6.6: Development of capacitor voltage transformer

There are numerous variations of this basic circuit. The inductance L may be a separate unit or it may be incorporated in the form of leakage reactance in the transformer T . Capacitors C_1 and C_2 cannot conveniently be made to close tolerances, so tapings are provided for ratio adjustment, either on the transformer T , or on a separate auto-transformer in the secondary circuit. Adjustment of the tuning inductance L is also needed; this can be done with tapings, a separate tapped inductor in the secondary circuit, by adjustment of gaps in the iron cores, or by shunting with variable capacitance. A simplified equivalent circuit is shown in Figure 6.7.

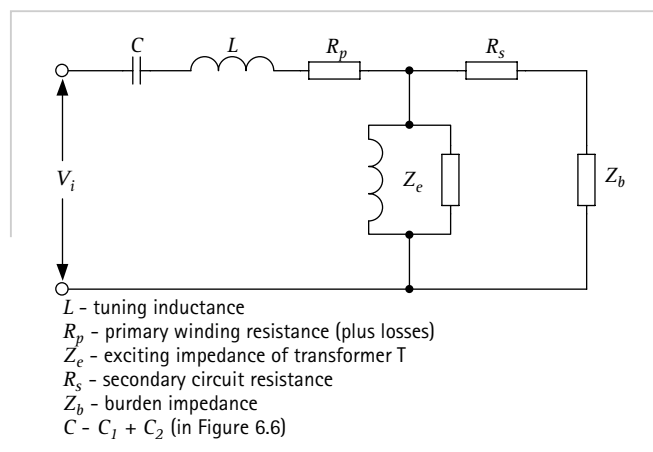

Figure 6.7: Simplified equivalent circuit of capacitor voltage transformer

It will be seen that the basic difference between Figure 6.7 and Figure 6.1 is the presence of C and L . At normal frequency when C and L are in resonance and therefore

cancel, the circuit behaves in a similar manner to a conventional VT. At other frequencies, however, a reactive component exists which modifies the errors.

Standards generally require a CVT used for protection to conform to accuracy requirements of Table 6.2 within a frequency range of 97-103% of nominal. The corresponding frequency range of measurement CVT's is much less, 99%-101%, as reductions in accuracy for frequency deviations outside this range are less important than for protection applications.

6.3.1 Voltage Protection of Auxiliary Capacitor

If the burden impedance of a CVT were to be short-circuited, the rise in the reactor voltage would be limited only by the reactor losses and possible saturation, that is, to $Q \times E_2$ where E_2 is the no-load tapping point voltage and Q is the amplification factor of the resonant circuit. This value would be excessive and is therefore limited by a spark gap connected across the auxiliary capacitor. The voltage on the auxiliary capacitor is higher at full rated output than at no load, and the capacitor is rated for continuous service at this raised value. The spark gap will be set to flash over at about twice the full load voltage.

The effect of the spark gap is to limit the short-circuit current which the VT will deliver and fuse protection of the secondary circuit has to be carefully designed with this point in mind. Facilities are usually provided to earth the tapping point, either manually or automatically, before making any adjustments to tappings or connections.

6.3.2 Transient Behaviour of Capacitor Voltage Transformers

A CVT is a series resonant circuit. The introduction of the electromagnetic transformer between the intermediate voltage and the output makes possible further resonance involving the exciting impedance of this unit and the capacitance of the divider stack. When a sudden voltage step is applied, oscillations in line with these different modes take place, and will persist for a period governed by the total resistive damping that is present. Any increase in resistive burden reduces the time constant of a transient oscillation, although the chance of a large initial amplitude is increased.

For very high-speed protection, transient oscillations should be minimised. Modern capacitor voltage transformers are much better in this respect than their earlier counterparts, but high performance protection schemes may still be adversely affected.

6.3.3 Ferro-Resonance

The exciting impedance Z_e of the auxiliary transformer T

and the capacitance of the potential divider together form a resonant circuit that will usually oscillate at a sub-normal frequency. If this circuit is subjected to a voltage impulse, the resulting oscillation may pass through a range of frequencies. If the basic frequency of this circuit is slightly less than one-third of the system frequency, it is possible for energy to be absorbed from the system and cause the oscillation to build up. The increasing flux density in the transformer core reduces the inductance, bringing the resonant frequency nearer to the one-third value of the system frequency.

The result is a progressive build-up until the oscillation stabilizes as a third sub-harmonic of the system, which can be maintained indefinitely. Depending on the values of components, oscillations at fundamental frequency or at other sub-harmonics or multiples of the supply frequency are possible but the third sub-harmonic is the one most likely to be encountered.

The principal manifestation of such an oscillation is a rise in output voltage, the r.m.s. value being perhaps 25%-50% above the normal value; the output waveform would generally be of the form shown in Figure 6.8.

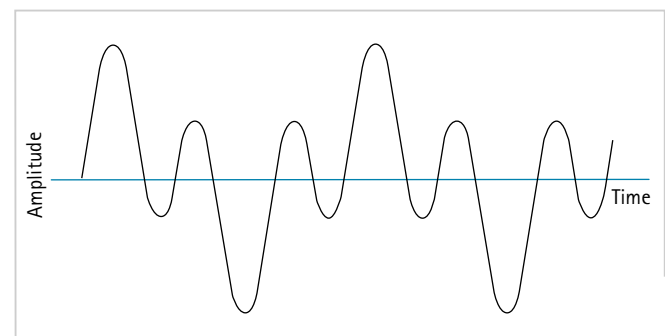

Figure 6.8: Typical secondary voltage waveform with third sub-harmonic oscillation.

Such oscillations are less likely to occur when the circuit losses are high, as is the case with a resistive burden, and can be prevented by increasing the resistive burden. Special anti-ferro-resonance devices that use a parallel-tuned circuit are sometimes built into the VT. Although such arrangements help to suppress ferro-resonance, they tend to impair the transient response, so that the design is a matter of compromise.

Correct design will prevent a CVT that supplies a resistive burden from exhibiting this effect, but it is possible for non-linear inductive burdens, such as auxiliary voltage transformers, to induce ferro-resonance. Auxiliary voltage transformers for use with capacitor voltage transformers should be designed with a low value of flux density that prevents transient voltages from causing core saturation, which in turn would bring high exciting currents.

6.4 CURRENT TRANSFORMERS

The primary winding of a current transformer is connected in series with the power circuit and the impedance is negligible compared with that of the power circuit. The power system impedance governs the current passing through the primary winding of the current transformer. This condition can be represented by inserting the load impedance, referred through the turns ratio, in the input connection of Figure 6.1.

This approach is developed in Figure 6.9, taking the numerical example of a 300/5A CT applied to an 11kV power system. The system is considered to be carrying rated current (300A) and the CT is feeding a burden of 10VA.

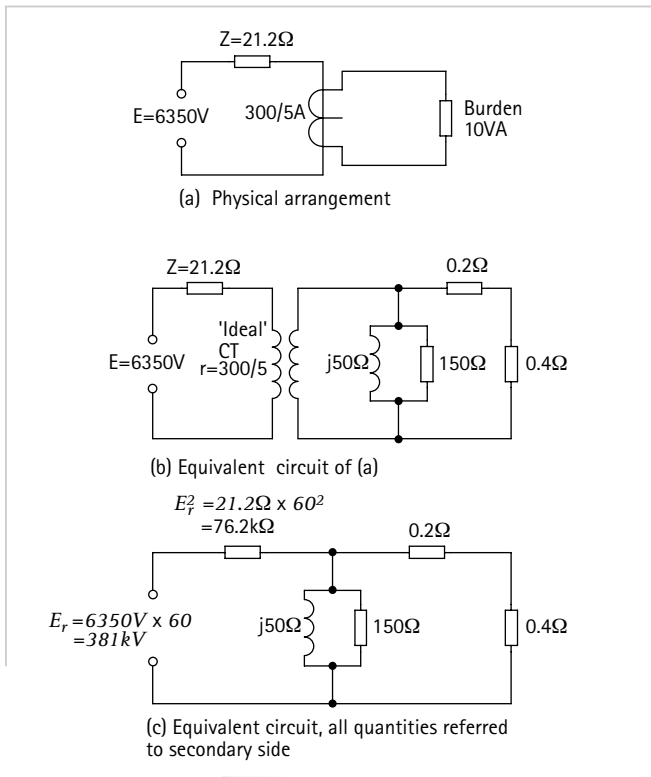

Figure 6.9: Derivation of equivalent circuit of a current transformer

A study of the final equivalent circuit of Figure 6.9(c), taking note of the typical component values, will reveal all the properties of a current transformer. It will be seen that:

- the secondary current will not be affected by change of the burden impedance over a considerable range
- the secondary circuit must not be interrupted while the primary winding is energised. The induced secondary e.m.f. under these circumstances will be high enough to present a danger to life and insulation
- the ratio and phase angle errors can be calculated easily if the magnetising characteristics and the burden impedance are known

6.4.1 Errors

The general vector diagram (Figure 6.2) can be simplified by the omission of details that are not of interest in current measurement; see Figure 6.10. Errors arise because of the shunting of the burden by the exciting impedance. This uses a small portion of the input current for exciting the core, reducing the amount passed to the burden. So $I_s = I_p - I_e$, where I_e is dependent on Z_e , the exciting impedance and the secondary e.m.f. E_s , given by the equation $E_s = I_s (Z_s + Z_b)$, where:

Z_s = the self-impedance of the secondary winding, which can generally be taken as the resistive component R_s only

Z_b = the impedance of the burden

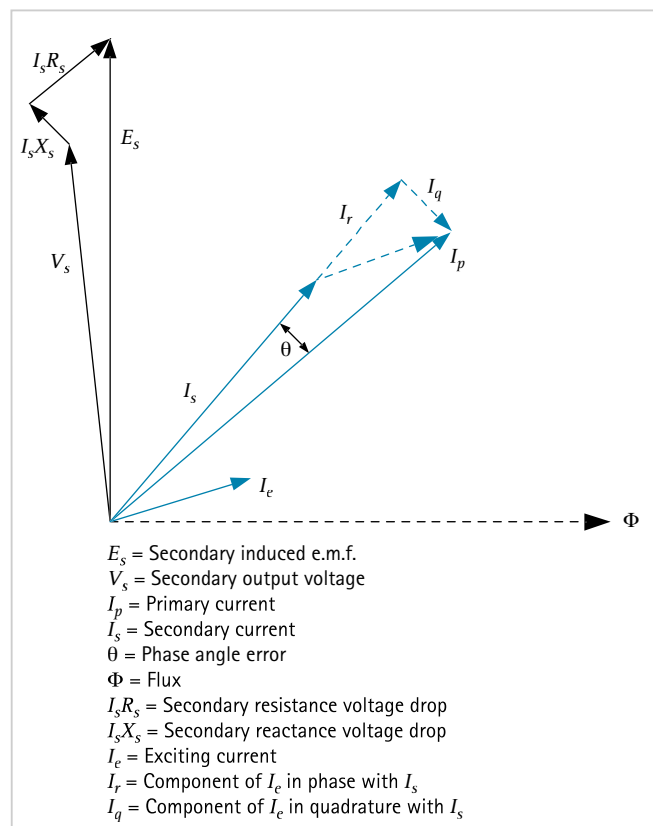

Figure 6.10: Vector diagram for current transformer (referred to secondary)

6.4.1.1 Current or Ratio Error

This is the difference in magnitude between I_p and I_s and is equal to I_r , the component of I_e which is in phase with I_s .

6.4.1.2 Phase Error

This is represented by I_q , the component of I_e in quadrature with I_s and results in the phase error ϕ .

The values of the current error and phase error depend on the phase displacement between I_s and I_e , but neither current nor phase error can exceed the vectorial error I_e . It will be seen that with a moderately inductive burden, resulting in I_s and I_e approximately in phase, there will

be little phase error and the exciting component will result almost entirely in ratio error.

A reduction of the secondary winding by one or two turns is often used to compensate for this. For example, in the CT corresponding to Figure 6.9, the worst error due to the use of an inductive burden of rated value would be about 1.2%. If the nominal turns ratio is 2:120, removal of one secondary turn would raise the output by 0.83% leaving the overall current error as -0.37%.

For lower value burden or a different burden power factor, the error would change in the positive direction to a maximum of +0.7% at zero burden; the leakage reactance of the secondary winding is assumed to be negligible. No corresponding correction can be made for phase error, but it should be noted that the phase error is small for moderately reactive burdens.

6.4.2 Composite Error

This is defined in IEC 60044-1 as the r.m.s. value of the difference between the ideal secondary current and the actual secondary current. It includes current and phase errors and the effects of harmonics in the exciting current. The accuracy class of measuring current transformers is shown in Table 6.4.

Accuracy class	% current	+/- Percentage current (ratio) error				+/- Phase displacement (minutes)			
		5	20	100	120	5	20	100	120
0.1		0.4	0.2	0.1	0.1	15	8	5	5
0.2		0.75	0.35	0.2	0.2	30	15	10	10
0.5		1.5	0.75	0.5	0.5	90	45	30	30
1		3	1.5	1.0	1.0	180	90	60	60

(a) Limits of error accuracy for error classes 0.1 - 1.0

Accuracy class	% current	+/- current (ratio) error, %	
		50	120
3		3	3
5		5	5

(b) Limits of error for error classes 3 and 5

Table 6.4: CT error classes

6.4.3 Accuracy Limit Current of Protection Current Transformers

Protection equipment is intended to respond to fault conditions, and is for this reason required to function at current values above the normal rating. Protection class current transformers must retain a reasonable accuracy up to the largest relevant current. This value is known as the 'accuracy limit current' and may be expressed in primary or equivalent secondary terms. The ratio of the accuracy limit current to the rated current is known as the 'accuracy limit factor'.

The accuracy class of protection current transformers is shown in Table 6.5.

Class	Current error at rated primary current (%)	Phase displacement at rated current (minutes)	Composite error at rated accuracy limit primary current (%)
5P	+/-1	+/-60	5
10P	+/-3		10

Standard accuracy limit factors are 5, 10, 15, 20, and 30

Table 6.5: Protection CT error limits for classes 5P and 10P

Even though the burden of a protection CT is only a few VA at rated current, the output required from the CT may be considerable if the accuracy limit factor is high. For example, with an accuracy limit factor of 30 and a burden of 10VA, the CT may have to supply 9000VA to the secondary circuit.

Alternatively, the same CT may be subjected to a high burden. For overcurrent and earth fault protection, with elements of similar VA consumption at setting, the earth fault element of an electromechanical relay set at 10% would have 100 times the impedance of the overcurrent elements set at 100%. Although saturation of the relay elements somewhat modifies this aspect of the matter, it will be seen that the earth fault element is a severe burden, and the CT is likely to have a considerable ratio error in this case. So it is not much use applying turns compensation to such current transformers; it is generally simpler to wind the CT with turns corresponding to the nominal ratio.

Current transformers are often used for the dual duty of measurement and protection. They will then need to be rated according to a class selected from both Tables 6.4 and 6.5. The applied burden is the total of instrument and relay burdens. Turns compensation may well be needed to achieve the measurement performance. Measurement ratings are expressed in terms of rated burden and class, for example 15VA Class 0.5. Protection ratings are expressed in terms of rated burden, class, and accuracy limit factor, for example 10VA Class 10P10.

6.4.4 Class PX Current Transformers

The classification of Table 6.5 is only used for overcurrent protection. Class PX is the definition in IEC 60044-1 for the quasi-transient current transformers formerly covered by Class X of BS 3938, commonly used with unit protection schemes.

Guidance was given in the specifications to the application of current transformers to earth fault protection, but for this and for the majority of other protection applications it is better to refer directly to the maximum useful e.m.f. that can be obtained from the CT. In this context, the 'knee-point' of the excitation curve is defined as 'that point at which a further increase of 10% of secondary e.m.f. would require an increment of exciting current of 50%'; see Figure 6.11.

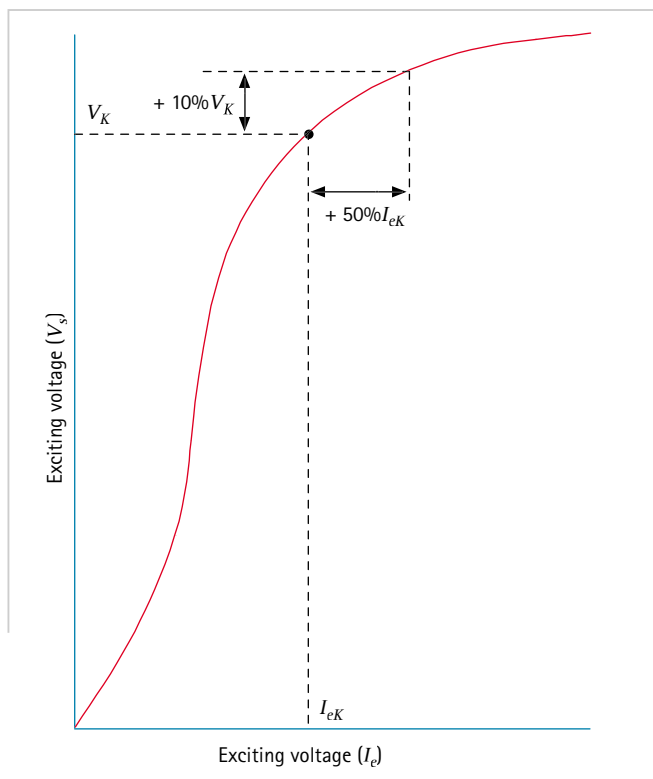

Figure 6.11: Definition of knee-point of excitation curve

Design requirements for current transformers for general protection purposes are frequently laid out in terms of knee-point e.m.f., exciting current at the knee-point (or some other specified point) and secondary winding resistance. Such current transformers are designated Class PX.

6.4.5 CT Winding Arrangements

A number of CT winding arrangements are used. These are described in the following sections.

6.4.5.1 Wound primary type

This type of CT has conventional windings formed of copper wire wound round a core. It is used for auxiliary current transformers and for many low or moderate ratio current transformers used in switchgear of up to 11kV rating.

6.4.5.2 Bushing or bar primary type

Many current transformers have a ring-shaped core, sometimes built up from annular stampings, but often consisting of a single length of strip tightly wound to form a close-turned spiral. The distributed secondary winding forms a toroid which should occupy the whole perimeter of the core, a small gap being left between start and finish leads for insulation.

Such current transformers normally have a single concentrically placed primary conductor, sometimes permanently built into the CT and provided with the

necessary primary insulation. In other cases, the bushing of a circuit breaker or power transformer is used for this purpose. At low primary current ratings it may be difficult to obtain sufficient output at the desired accuracy. This is because a large core section is needed to provide enough flux to induce the secondary e.m.f. in the small number of turns, and because the exciting ampere-turns form a large proportion of the primary ampere-turns available. The effect is particularly pronounced when the core diameter has been made large so as to fit over large EHV bushings.

6.4.5.3 Core-balance current transformers

The core-balance CT (or CBCT) is normally of the ring type, through the centre of which is passed cable that forms the primary winding. An earth fault relay, connected to the secondary winding, is energised only when there is residual current in the primary system.

The advantage in using this method of earth fault protection lies in the fact that only one CT core is used in place of three phase CT's whose secondary windings are residually connected. In this way the CT magnetising current at relay operation is reduced by approximately three-to-one, an important consideration in sensitive earth fault relays where a low effective setting is required. The number of secondary turns does not need to be related to the cable rated current because no secondary current would flow under normal balanced conditions. This allows the number of secondary turns to be chosen such as to optimise the effective primary pick-up current.

Core-balance transformers are normally mounted over a cable at a point close up to the cable gland of switchgear or other apparatus. Physically split cores ('slip-over' types) are normally available for applications in which the cables are already made up, as on existing switchgear.

6.4.5.4 Summation current transformers

The summation arrangement is a winding arrangement used in a measuring relay or on an auxiliary current transformer to give a single-phase output signal having a specific relationship to the three-phase current input.

6.4.5.5 Air-gapped current transformers

These are auxiliary current transformers in which a small air gap is included in the core to produce a secondary voltage output proportional in magnitude to current in the primary winding. Sometimes termed 'transactors' and 'quadrature current transformers', this form of current transformer has been used as an auxiliary component of unit protection schemes in which the outputs into multiple secondary circuits must remain linear for and proportioned to the widest practical range of input currents.

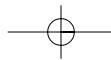

6.4.6 Line Current CT's

CT's for measuring line currents fall into one of three types.

6.4.6.1 Overdimensioned CT's

Overdimensioned CT's are capable of transforming fully offset fault currents without distortion. In consequence, they are very large, as can be deduced from Section 6.4.10. They are prone to errors due to remanent flux arising, for instance, from the interruption of heavy fault currents.

6.4.6.2 Anti-remanence CT's

This is a variation of the overdimensioned current transformer and has small gap(s) in the core magnetic circuit, thus reducing the possible remanent flux from approximately 90% of saturation value to approximately 10%. These gap(s) are quite small, for example 0.12mm total, and so the excitation characteristic is not significantly changed by their presence. However, the resulting decrease in possible remanent core flux confines any subsequent d.c. flux excursion, resulting from primary current asymmetry, to within the core saturation limits. Errors in current transformation are therefore significantly reduced when compared with those with the gapless type of core.

Transient protection current transformers are included in IEC 60044-6 as types TPX, TPY and TPZ and this specification gives good guidance to their application and use.

6.4.6.3 Linear current transformers

The 'linear' current transformer constitutes an even more radical departure from the normal solid core CT in that it incorporates an appreciable air gap, for example 7.5-



Figure 6.12: Typical modern CT for use on MV systems

10mm. As its name implies the magnetic behaviour tends to linearisation by the inclusion of this gap in the magnetic circuit. However, the purpose of introducing more reluctance into the magnetic circuit is to reduce the value of magnetising reactance. This in turn reduces the secondary time-constant of the CT, thereby reducing the overdimensioning factor necessary for faithful transformation. Figure 6.12 shows a typical modern CT for use on MV systems.

6.4.7 Secondary Winding Impedance

As a protection CT may be required to deliver high values of secondary current, the secondary winding resistance must be made as low as practicable. Secondary leakage reactance also occurs, particularly in wound primary current transformers, although its precise measurement is difficult. The non-linear nature of the CT magnetic circuit makes it difficult to assess the definite ohmic value representing secondary leakage reactance.

It is, however, normally accepted that a current transformer is of the low reactance type provided that the following conditions prevail:

- a. the core is of the jointless ring type (including spirally wound cores)
- b. the secondary turns are substantially evenly distributed along the whole length of the magnetic circuit
- c. the primary conductor(s) passes through the approximate centre of the core aperture or, if wound, is approximately evenly distributed along the whole length of the magnetic circuit
- d. flux equalising windings, where fitted to the requirements of the design, consist of at least four parallel-connected coils, evenly distributed along the whole length of the magnetic circuit, each coil occupying one quadrant

Alternatively, when a current transformer does not obviously comply with all of the above requirements, it may be proved to be of low-reactance where:

- e. the composite error, as measured in the accepted way, does not exceed by a factor of 1.3 that error obtained directly from the V-I excitation characteristic of the secondary winding

6.4.8 Secondary Current Rating

The choice of secondary current rating is determined largely by the secondary winding burden and the standard practice of the user. Standard CT secondary current ratings are 5A and 1A. The burden at rated current imposed by digital or numerical relays or

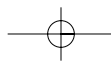

instruments is largely independent of the rated value of current. This is because the winding of the device has to develop a given number of ampere-turns at rated current, so that the actual number of turns is inversely proportional to the current, and the impedance of the winding varies inversely with the square of the current rating. However, electromechanical or static earth-fault relays may have a burden that varies with the current tapping used.

Interconnection leads do not share this property, however, being commonly of standard cross-section regardless of rating. Where the leads are long, their resistance may be appreciable, and the resultant burden will vary with the square of the current rating. For example a CT lead run of the order of 200 metres, a typical distance for outdoor EHV switchgear, could have a loop resistance of approximately 3 ohms.

The CT lead VA burden if a 5A CT is used would be 75VA, to which must be added the relay burden (up to of perhaps 10VA for an electromechanical relay, but less than 1VA for a numerical relay), making a total of 85VA. Such a burden would require the CT to be very large and expensive, particularly if a high accuracy limit factor were also applicable.

With a 1A CT secondary rating, the lead burden is reduced to 3VA, so that with the same relay burden the total becomes a maximum of 13VA. This can be provided by a CT of normal dimensions, resulting in a saving in size, weight and cost. Hence modern CT's tend to have secondary windings of 1A rating. However, where the primary rating is high, say above 2000A, a CT of higher secondary rating may be used, to limit the number of secondary turns. In such a situation secondary ratings of 2A, 5A or, in extreme cases, 20A, might be used.

6.4.9 Rated Short-Time Current

A current transformer is overloaded while system short-circuit currents are flowing and will be short-time rated. Standard times for which the CT must be able to carry rated short-time current (STC) are 0.25, 0.5, 1.0, 2.0 or 3.0 seconds.

A CT with a particular short-time current/ time rating will carry a lower current for a longer time in inverse proportion to the square of the ratio of current values. The converse, however, cannot be assumed, and larger current values than the S.T.C. rating are not permissible for any duration unless justified by a new rating test to prove the dynamic capability.

6.4.10 Transient Response of a Current Transformer

When accuracy of response during very short intervals is being studied, it is necessary to examine what happens

when the primary current is suddenly changed. The effects are most important, and were first observed in connection with balanced forms of protection, which were liable to operate unnecessarily when short-circuit currents were suddenly established.

6.4.10.1 Primary current transient

The power system, neglecting load circuits, is mostly inductive, so that when a short circuit occurs, the fault current that flows is given by:

$$i_p = \frac{E_p}{\sqrt{R^2 + \omega^2 L^2}}$$

$$\left[\sin(\omega t + \beta - \alpha) + \sin(\alpha - \beta) e^{-(R/L)t} \right] \dots \text{Equation 6.1}$$

where:

- E_p = peak system e.m.f.
- R = system resistance
- L = system inductance
- β = initial phase angle governed by instant of fault occurrence
- α = system power factor angle
= $\tan^{-1} \omega L/R$

The first term of Equation 6.1 represents the steady state alternating current, while the second is a transient quantity responsible for displacing the waveform asymmetrically.

$$\frac{E_p}{\sqrt{R^2 + \omega^2 L^2}} \text{ is the steady state peak current } I_p.$$

The maximum transient occurs when $\sin(\alpha - \beta) = 1$; no other condition need be examined.

So:

$$i_p = I_p \left[\sin\left(\omega t - \frac{\pi}{2}\right) + e^{-(R/L)t} \right] \dots \text{Equation 6.2}$$

When the current is passed through the primary winding of a current transformer, the response can be examined by replacing the CT with an equivalent circuit as shown in Figure 6.9(b).

As the 'ideal' CT has no losses, it will transfer the entire function, and all further analysis can be carried out in terms of equivalent secondary quantities (i_s and I_s). A simplified solution is obtainable by neglecting the exciting current of the CT.

The flux developed in an inductance is obtained by integrating the applied e.m.f. through a time interval:

$$\phi = K \int_{t_1}^{t_2} v dt \dots \text{Equation 6.3}$$

For the CT equivalent circuit, the voltage is the drop on

the burden resistance R_b .

Integrating for each component in turn, the steady state peak flux is given by:

$$\begin{aligned} \phi_A &= KR_b I_s \int_{\pi/\omega}^{3\pi/2\omega} \sin\left(\omega t - \frac{\pi}{2}\right) dt \\ &= \frac{KR_b I_s}{\omega} \end{aligned} \quad \dots\text{Equation 6.4}$$

The transient flux is given by:

$$\phi_B = KR_b I_s \int_0^\alpha e^{-(R/L)t} dt = \frac{KR_b I_s L}{R} \quad \dots\text{Equation 6.5}$$

Hence, the ratio of the transient flux to the steady state value is:

$$\frac{\phi_B}{\phi_A} = \frac{\omega L}{R} = \frac{X}{R}$$

where X and R are the primary system reactance and resistance values.

The CT core has to carry both fluxes, so that:

$$\phi_C = \phi_A + \phi_B = \phi_A \left(1 + \frac{X}{R}\right) \quad \dots\text{Equation 6.6}$$

The term $(1+X/R)$ has been called the 'transient factor' (TF), the core flux being increased by this factor during the transient asymmetric current period. From this it can be seen that the ratio of reactance to resistance of the power system is an important feature in the study of the behaviour of protection relays.

Alternatively, L/R is the primary system time constant T , so that the transient factor can be written:

$$= 1 + \frac{\omega L}{R} = 1 + \omega T$$

Again, fT is the time constant expressed in cycles of the a.c. quantity T' , so that:

$$TF = 1 + 2\pi fT = 1 + 2\pi T'$$

This latter expression is particularly useful when assessing a recording of a fault current, because the time constant in cycles can be easily estimated and leads directly to the transient factor. For example, a system time constant of three cycles results in a transient factor of $(1+6\pi)$, or 19.85; that is, the CT would be required to handle almost twenty times the maximum flux produced under steady state conditions.

The above theory is sufficient to give a general view of the problem. In this simplified treatment, no reverse voltage is applied to demagnetise the CT, so that the flux would build up as shown in Figure 6.13.

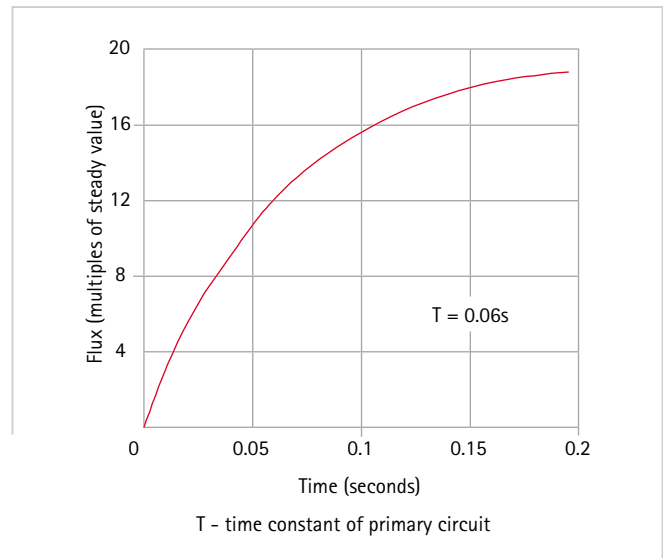

Figure 6.13: Response of a CT of infinite shunt impedance to transient asymmetric primary current

Since a CT requires a finite exciting current to maintain a flux, it will not remain magnetised (neglecting hysteresis), and for this reason a complete representation of the effects can only be obtained by including the finite inductance of the CT in the calculation. The response of a current transformer to a transient asymmetric current is shown in Figure 6.14.

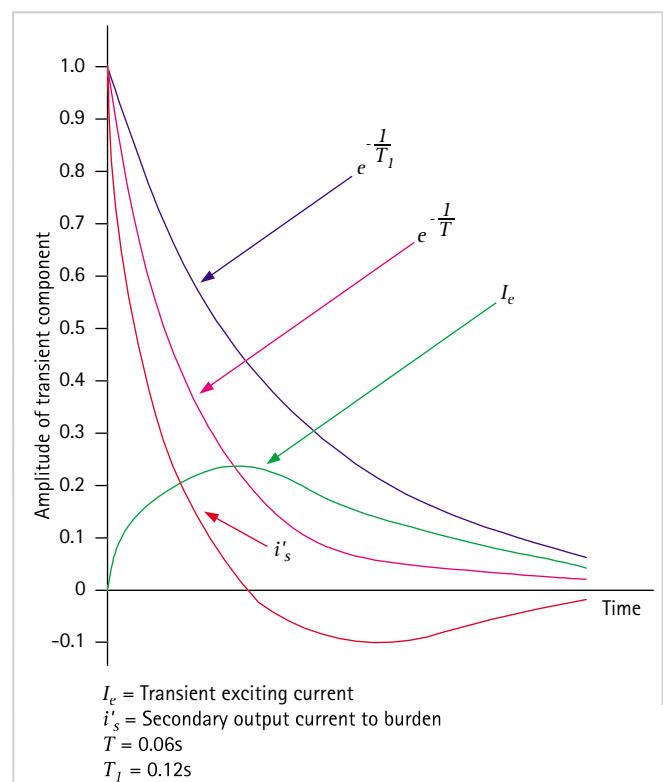
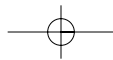

Figure 6.14: Response of a current transformer to a transient asymmetric current



Let:

$i_s = \text{the nominal secondary current}$

$i'_s = \text{the actual secondary output current}$

$i_e = \text{the exciting current}$

then:

$$i_s = i_e + i'_s \quad \dots \text{Equation 6.7}$$

also,

$$L_e \frac{di_e}{dt} = R_b i'_s \quad \dots \text{Equation 6.8}$$

whence:

$$\frac{di_e}{dt} + \frac{R_b i_e}{L_e} = \frac{R_b i_s}{L_e} \quad \dots \text{Equation 6.9}$$

which gives for the transient term

$$i_e = I_1 \frac{T}{T_1 - T} (e^{-t/T_1} - e^{-t/T})$$

where:

$T = \text{primary system time constant } L/R$

$T_1 = \text{CT secondary circuit time constant } L_e/R_b$

$I_1 = \text{prospective peak secondary current}$

6.4.10.2 Practical conditions

Practical conditions differ from theory for the following reasons:

- no account has been taken of secondary leakage or burden inductance. This is usually small compared with L_e so that it has little effect on the maximum transient flux
- iron loss has not been considered. This has the effect of reducing the secondary time constant, but the value of the equivalent resistance is variable, depending upon both the sine and exponential terms. Consequently, it cannot be included in any linear theory and is too complicated for a satisfactory treatment to be evolved
- the theory is based upon a linear excitation characteristic. This is only approximately true up to the knee-point of the excitation curve. A precise solution allowing for non-linearity is not practicable. Solutions have been sought by replacing the excitation curve with a number of chords; a linear analysis can then be made for the extent of each chord

The above theory is sufficient, however, to give a good insight into the problem and to allow most practical issues to be decided.

- the effect of hysteresis, apart from loss as discussed under (b) above, is not included. Hysteresis makes the inductance different for flux build up and decay, so that the secondary time constant is variable. Moreover, the ability of the

core to retain a 'remanent' flux means that the value of ϕ_B developed in Equation 6.5 has to be regarded as an increment of flux from any possible remanent value positive or negative. The formula would then be reasonable provided the applied current transient did not produce saturation

It will be seen that a precise calculation of the flux and excitation current is not feasible; the value of the study is to explain the observed phenomena. The asymmetric (or d.c.) component can be regarded as building up the mean flux over a period corresponding to several cycles of the sinusoidal component, during which period the latter component produces a flux swing about the varying 'mean level' established by the former. The asymmetric flux ceases to increase when the exciting current is equal to the total asymmetric input current, since beyond this point the output current, and hence the voltage drop across the burden resistance, is negative. Saturation makes the point of equality between the excitation current and the input occur at a flux level lower than would be expected from linear theory.

When the exponential component drives the CT into saturation, the magnetising inductance decreases, causing a large increase in the alternating component ie.

The total exciting current during the transient period is of the form shown in Figure 6.15 and the corresponding resultant distortion in the secondary current output, due to saturation, is shown in Figure 6.16.

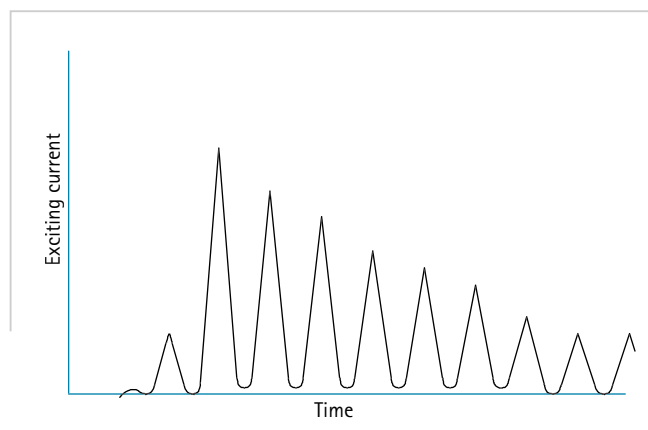

Figure 6.15: Typical exciting current of CT during transient asymmetric input current

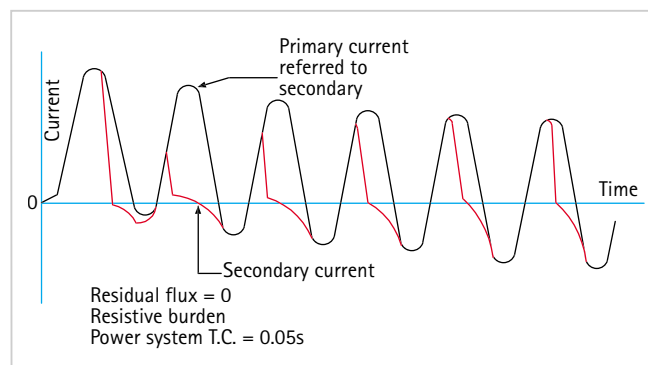
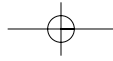

Figure 6.16: Distortion in secondary current due to saturation



The presence of residual flux varies the starting point of the transient flux excursion on the excitation characteristic. Remanence of like polarity to the transient will reduce the value of symmetric current of given time constant which the CT can transform without severe saturation; conversely, reverse remanence will greatly increase the ability of a CT to transform transient current.

If the CT were the linear non-saturable device considered in the analysis, the sine current would be transformed without loss of accuracy. In practice the variation in excitation inductance caused by transferring the centre of the flux swing to other points on the excitation curve causes an error that may be very large. The effect on measurement is of little consequence, but for protection equipment that is required to function during fault conditions, the effect is more serious. The output current is reduced during transient saturation, which may prevent the relays from operating if the conditions are near to the relay setting. This must not be confused with the increased r.m.s. value of the primary current due to the asymmetric transient, a feature which sometimes offsets the increase ratio error. In the case of balanced protection, during through faults the errors of the several current transformers may differ and produce an out-of-balance quantity, causing unwanted operation.

6.4.11 Harmonics during the Transient Period

When a CT is required to develop a high secondary e.m.f. under steady state conditions, the non-linearity of the excitation impedance causes some distortion of the output waveform; such a waveform will contain, in addition to the fundamental current, odd harmonics only.

When, however, the CT is saturated uni-directionally while being simultaneously subjected to a small a.c. quantity, as in the transient condition discussed above, the output will contain both odd and even harmonics. Usually the lower numbered harmonics are of greatest amplitude and the second and third harmonic components may be of considerable value. This may affect relays that are sensitive to harmonics.

6.4.12 Test Windings

On-site conjunctive testing of current transformers and the apparatus that they energise is often required. It may be difficult, however, to pass a suitable value of current through the primary windings, because of the scale of such current and in many cases because access to the primary conductors is difficult. Additional windings may be provided to make such tests easier, these windings usually being rated at 10A. The test winding will inevitably occupy appreciable space and the

CT will cost more. This fact should be weighed against the convenience achieved; very often it will be found that the tests in question can be replaced by alternative procedures.

6.5 NOVEL INSTRUMENT TRANSFORMERS

The preceding types of instrument transformers have all been based on electromagnetic principles using a magnetic core. There are now available several new methods of transforming the measured quantity using optical and mass state methods.

6.5.1 Optical Instrument Transducers

The key features of a freestanding optical instrument transducer can be illustrated with the functional diagram of Figure 6.17.

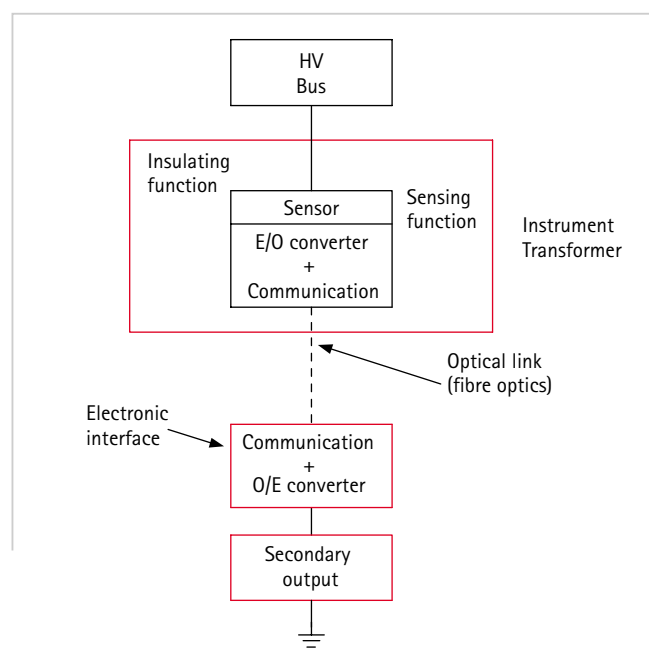

Figure 6.17: Functional diagram of optical instrument transducer

Optical converters and optical glass fibre channels implement the link between the sensor and the low-voltage output. The fundamental difference between an instrument transducer and a conventional instrument transformer is the electronic interface needed for its operation. This interface is required both for the sensing function and for adapting the new sensor technology to that of the secondary output currents and voltages.

Non-conventional optical transducers lend themselves to smaller, lighter devices where the overall size and power rating of the unit does not have any significant bearing on the size and the complexity of the sensor. Small, lightweight insulator structures may be tailor-made to

fit optical sensing devices as an integral part of the insulator. Additionally, the non-linear effects and electromagnetic interference problems in the secondary wiring of conventional VT's and CT's are minimised.

Optical transducers can be separated in two families: firstly the *hybrid* transducers, making use of conventional electrical circuit techniques to which are coupled various optical converter systems, and secondly the *'all-optical'* transducers that are based on fundamental, optical sensing principles.

6.5.1.1 Optical sensor concepts

Certain optical sensing media (glass, crystals, plastics) show a sensitivity to electric and magnetic fields and that some properties of a probing light beam can be altered when passing through them. One simple optical transducer description is given here in Figure. 6.18.

Consider the case of a beam of light passing through a pair of polarising filters. If the input and output polarising filters have their axes rotated 45° from each other, only half the light will come through. The reference light input intensity is maintained constant over time. Now if these two polarising filters remain fixed and a third polarising filter is placed in between them, a random rotation of this middle polariser either clockwise or counter-clockwise will be monitored as a varying or modulated light output intensity at the light detector.

When a block of optical sensing material (glass or crystal) is immersed in a varying magnetic or electric

field, it plays the role of the 'odd' polariser. Changes in the magnetic or electric field in which the optical sensor is immersed are monitored as a varying intensity of the probing light beam at the light detector. The light output intensity fluctuates around the zero-field level equal to 50% of the reference light input.

A transducer uses a magneto-optic effect sensor for optical current measuring applications. This reflects the fact that the sensor is not basically sensitive to a current but to the magnetic field generated by this current. Although 'all-fibre' approaches are feasible, most commercially available optical current transducers rely on a bulk-glass sensor. Most optical voltage transducers, on the other hand, rely on an electro-optic effect sensor. This reflects the fact that the sensor used is sensitive to the imposed electric field.

6.5.1.2 Hybrid transducers

The hybrid family of non-conventional instrument transducers can be divided in two types: those with active sensors and those with passive sensors. The idea behind a transducer with an active sensor is to change the existing output of the conventional instrument transformer into an optically isolated output by adding an optical conversion system (Figure 6.18). This conversion system may require a power supply of its own: this is the active sensor type. The use of an optical isolating system serves to de-couple the instrument transformer output secondary voltages and currents

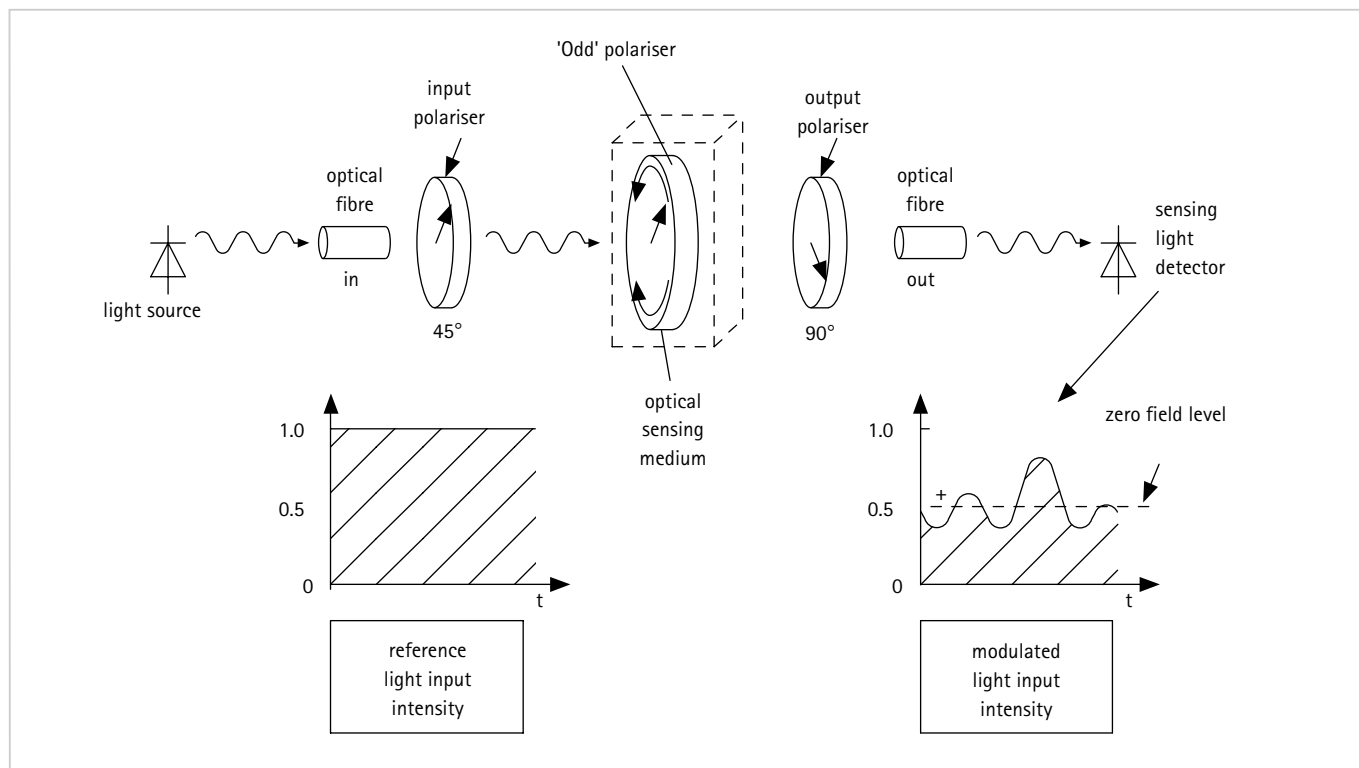

Figure. 6.18: Schematic representation of the concepts behind the optical sensing of varying electric and magnetic fields

from earthed or galvanic links. Thus the only link that remains between the control-room and the switchyard is a fibre optic cable.

Another type of hybrid non-conventional instrument transformer is achieved by retrofitting a passive optical sensing medium into a conventional 'hard-wire secondary' instrument transformer. This can be termed as a passive hybrid type since no power supply of any kind is needed at the secondary level.

6.5.1.3 'All-optical' transducers

These instrument transformers are based entirely on optical materials and are fully passive. The sensing function is achieved directly by the sensing material and a simple fibre optic cable running between the base of the unit and the sensor location provides the communication link.

The sensing element is made of an optical material that is positioned in the electric or magnetic field to be sensed. In the case of a current measuring device the sensitive element is either located free in the magnetic field (Figure 6.19(a)) or it can be immersed in a field-shaping magnetic 'gap' (Figure 6.19(b)). In the case of a voltage-sensing device (Figure 6.20) the same alternatives exist, this time for elements that are sensitive to electric fields. The possibility exists of combining both sensors within a single housing, thus providing both a CT and VT within a single compact housing that gives rise to space savings within a substation.

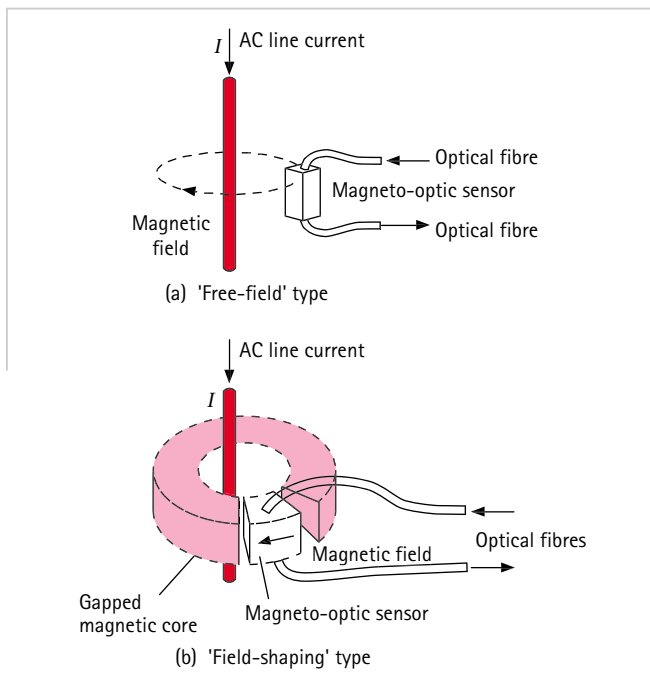

Figure 6.19: Optical current sensor based on the magnetic properties of optical materials

In all cases there is an optical fibre that channels the probing reference light from a source into the medium and another fibre that channels the light back to

analysing circuitry. In sharp contrast with a conventional free-standing instrument transformer, the optical instrument transformer needs an electronic interface module in order to function. Therefore its sensing principle (the optical material) is passive but its operational integrity relies on the interface that is powered in the control room (Figure 6.21).

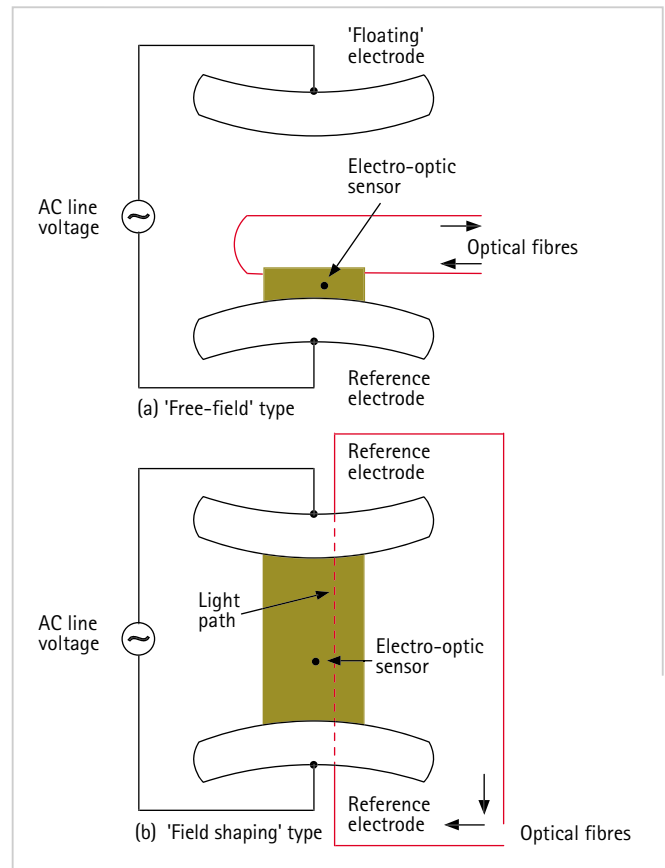

Figure 6.20: Optical voltage sensor based on the electrical properties of optical materials

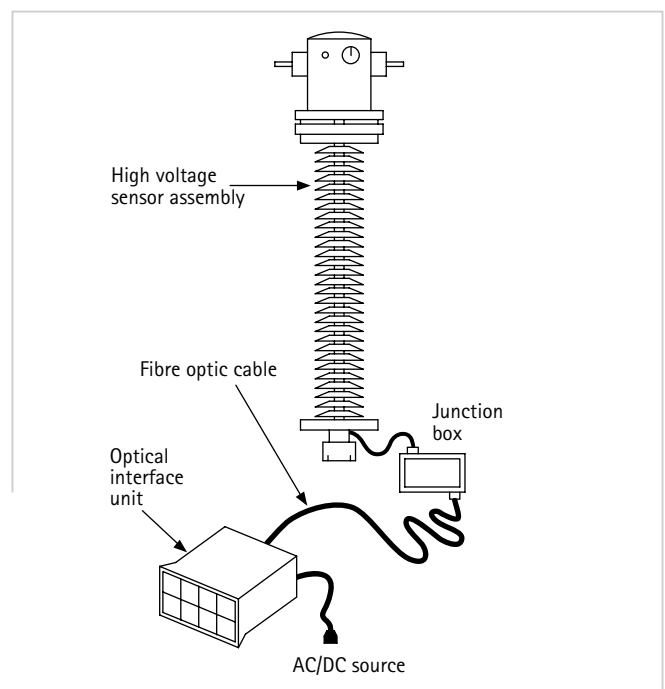

Figure 6.21: Novel instrument transducer concept requiring an electronic interface in the control room

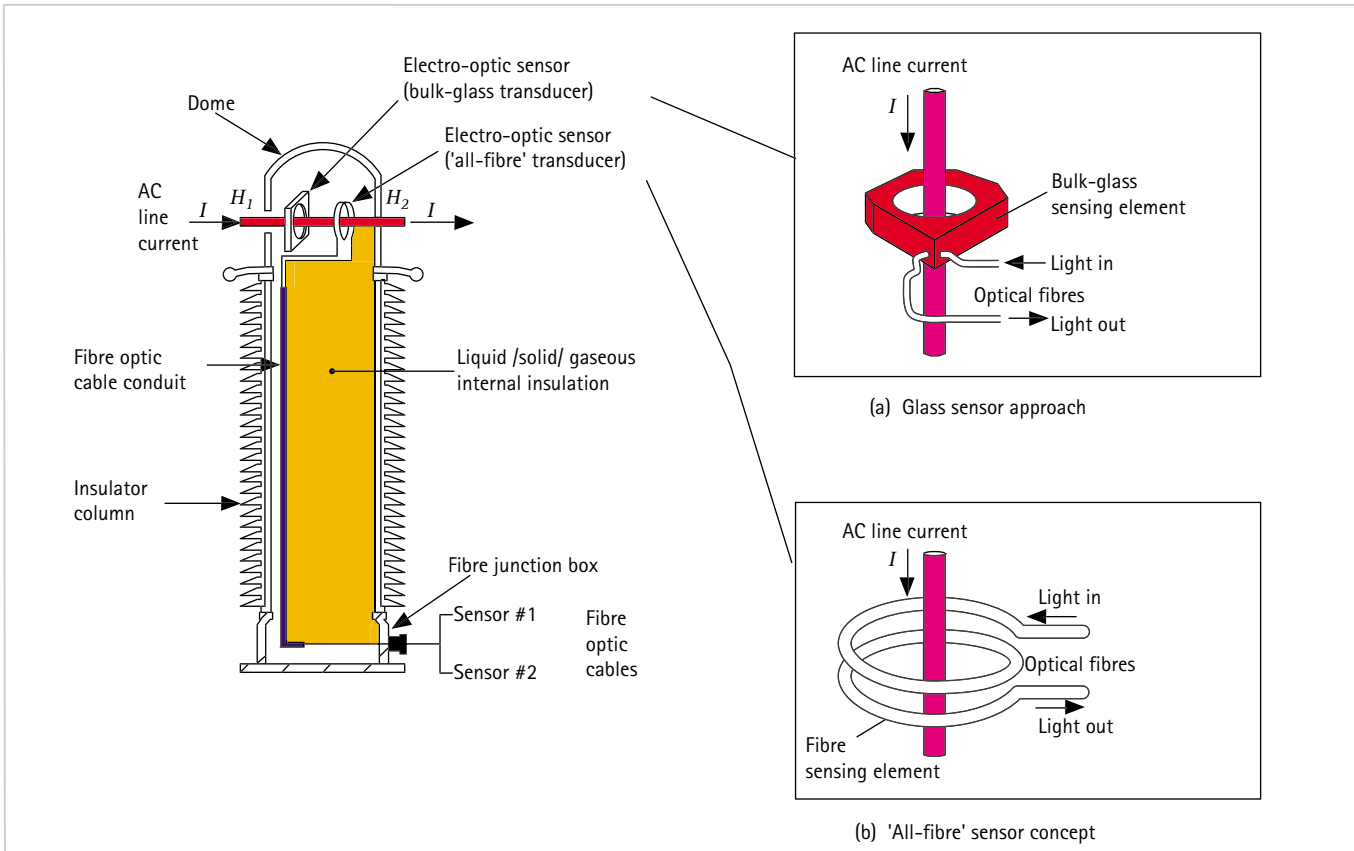

Figure 6.22: Conceptual design of a double-sensor optical CT

Similar to conventional instrument transformers there are 'live tank' and 'dead tank' optical transducers. Typically, current transducers take the shape of a closed loop of light-transparent material, fitted around a straight conductor carrying the line current (Figure 6.22). In this case a bulk-glass sensor unit is depicted (Figure 6.22(a)), along with an 'all-optical' sensor example, as shown in Figure 6.22(b). Light detectors are basically very sensitive devices and the sensing material can thus be selected in such a way as to scale-up readily for larger currents. 'All-optical' voltage transducers however do not lend themselves easily for extremely high line voltages. Two concepts using a 'full-voltage' sensor are shown in Figure 6.23.

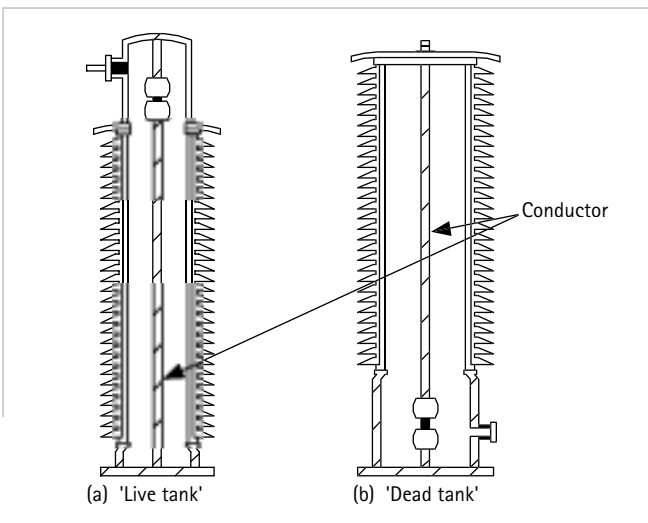

Figure 6.23: Optical voltage transducer concepts, using a 'full-voltage' sensor

Although 'all-optical' instrument transformers were first introduced 10-15 years ago, there are still only a few in service nowadays. Figure 6.24 shows a field installation of a combined optical CT/VT.



Figure 6.24: Field installation of a combined optical CT/VT

6.5.2 Other Sensing Systems

There are a number of other sensing systems that can be used, as described below.

6.5.2.1 Zero-flux (Hall Effect) current transformer

In this case the sensing element is a semi-conducting wafer that is placed in the gap of a magnetic concentrating ring. This type of transformer is also sensitive to d.c. currents. The transformer requires a power supply that is fed from the line or from a separate power supply. The sensing current is typically 0.1% of the current to be measured. In its simplest shape, the Hall effect voltage is directly proportional to the magnetising current to be measured. For more accurate and more sensitive applications, the sensing current is fed through a secondary, multiple-turn winding, placed around the magnetic ring in order to balance out the gap magnetic field. This zero-flux or null-flux version allows very accurate current measurements in both d.c. and high-frequency applications. A schematic representation of the sensing part is shown in Figure 6.25.

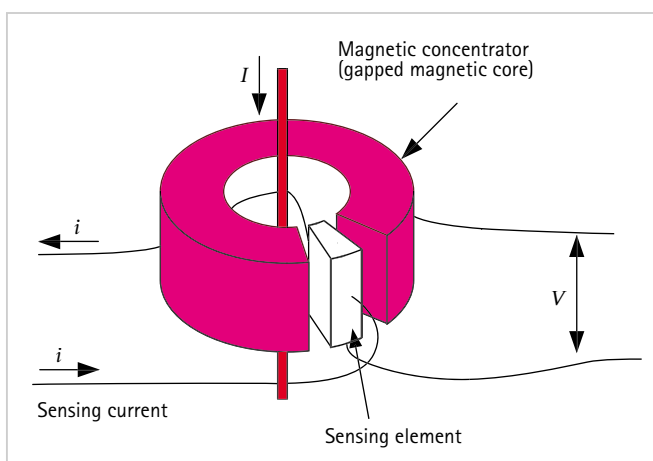

Figure 6.25: Conceptual design of a Hall-effect current sensing element fitted in a field-shaping gap

6.5.2.2 Hybrid magnetic-optical sensor

This type of transformer is mostly used in applications such as series capacitive compensation of long transmission lines, where a non-grounded measurement of current is required. In this case, several current sensors are required on each phase in order to achieve capacitor surge protection and balance. The preferred solution is to use small toroidally wound magnetic core transformers connected to fibre optic isolating systems. These sensors are usually active sensors in the sense that the isolated systems require a power supply. This is illustrated in Figure 6.26.

6.5.2.3 Rogowski coils

The Rogowski coil is based on the principle of an air-cored current transformer with a very high load impedance. The secondary winding is wound on a toroid

of insulation material. In most cases the Rogowski coil will be connected to an amplifier, in order to deliver sufficient power to the connected measuring or protection equipment and to match the input impedance of this equipment. The Rogowski coil requires integration of the magnetic field and therefore has a time and phase delay whilst the integration is completed. This can be corrected for within a digital protection relay. The schematic representation of the Rogowski coil sensor is shown in Figure 6.27.

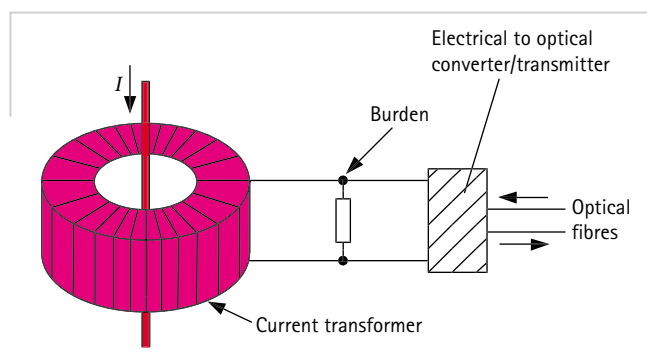

Figure 6.26: Design principle of a hybrid magnetic current transformer fitted with an optical transmitter

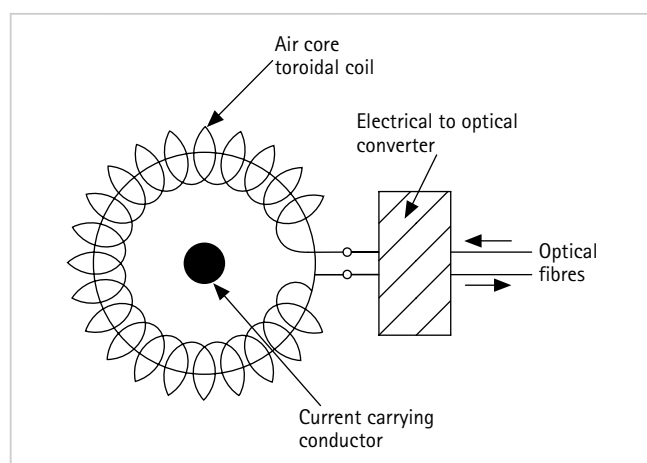

Figure 6.27: Schematic representation of a Rogowski coil, used for current sensing